



# BAGGAGE CAROUSELS

THE LATEST STANDARD IN DESIGN AND RELIABILITY



## HIGH STANDARDS

For over 50 years Vanderlande has supplied airports with baggage carousels for claim and make-up. An installed base of over 1500 units proves the reliability and competitiveness of the Vanderlande Industries baggage carousels. Their high flexibility enables tailor-made solutions to be created that optimally utilise the available space. The modular design concept also permits easy alteration or expansion to meet future needs. Life Cycle Costs are reduced to a minimum thanks to almost zero maintenance of the systems and the use of high-reliability components. As a result, a unique 5-year guarantee is offered.

### Robust and attractive design

All the Vanderlande Industries carousels are based on the same standard components:

- A series of carriers, running in a steel track and connected by a robust aluminium chain
- The chain is driven by a unique friction drive, ensuring high reliability without the need for lubrication
- A controls cabinet based on industry-standard technology and components
- Clean lines with high-quality stainless steel finishing and no visible fasteners in public areas

### Highest availability through simple maintenance

If maintenance is needed, the carousels are designed for easy, efficient maintenance with fast operator accessibility of key components.

The modular design means only limited numbers of spare parts are needed.

In general, only one maintenance inspection is needed each year.

Components are selected specifically for low maintenance requirements, and the Vanderlande Industries carousels therefore offer today's highest operational availability levels.

### Smooth and quiet operation

Regardless of whether floors are level or uneven, operation remains smooth and quiet with low component wear, thanks to individually adjustable ball-and-socket joints on the system supports. High reliability and almost silent operation are provided by the unique friction drive system, without the wear and tear and lubrication requirements of conventional chain drive systems.



## VARIOUS TYPES TO SUIT EVERY NEED

Vanderlande Industries carousels are available in four different types for both baggage claim and make-up. Each type has its own specific application features.

### TRIPLANAR FLAT

- Overlapping, black, antistatic slats
- Ergonomically sound loading and unloading, usually manual

### TRIPLANAR TILTED

- Inclined, overlapping, black, antistatic slats
- Also available with overlapping stainless steel pallets
- Preferred loading by belt conveyor from top

### EASYCLAIM

- Combines the advantages of the flat and tilted versions:
- Ergonomically sound unloading
- Loading by belt conveyor from top

### CRESPLANAR

- Crescent-shaped durable steel pallets
- For heavy-duty applications

## Cross Sections

### TRIPLANAR FLAT

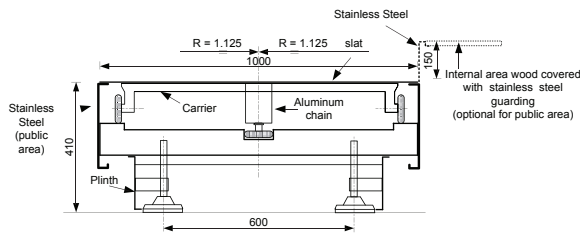

TRIPLANAR FLAT in make-up area

### TRIPLANAR TILTED

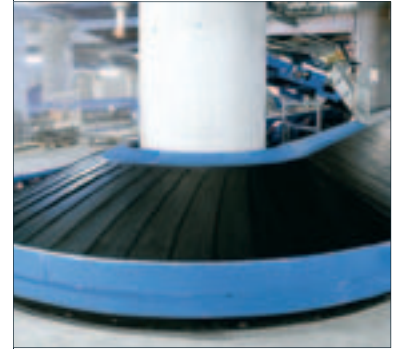
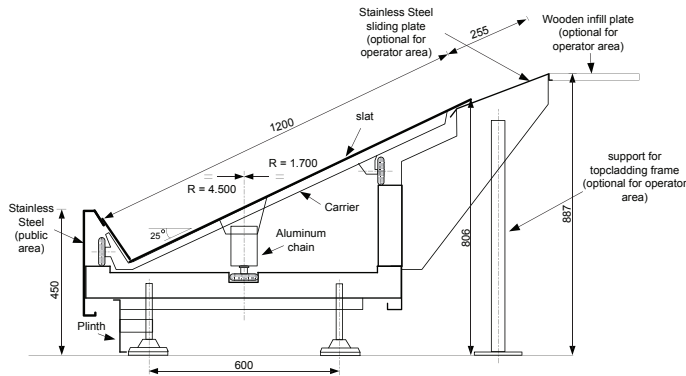

TRIPLANAR TILTED in make-up area

### EASYCLAIM

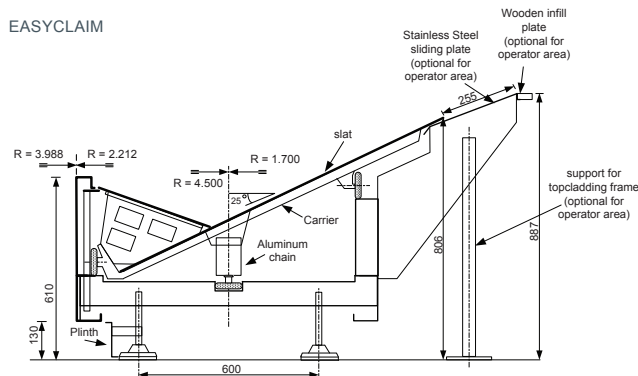

EASYCLAIM in make-up area

### CRESPLANAR

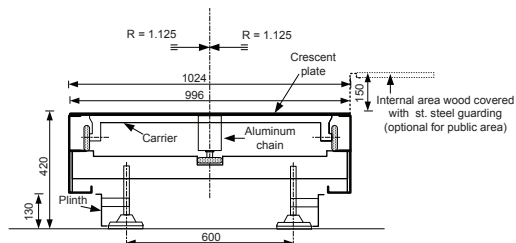

All dimensions in mm  
Stainless steel only in public areas